

AUTHORISED ITEMS for WATER RETICULATION SYSTEM

WATER CONNECTIONS

***ALL MINOR ITEMS NOT COVERED IN DETAIL IN THIS CATALOGUE TO
BE IN ACCORDANCE TO APPROPRIATE AUSTRALIAN STANDARD.***

Further information on products and materials is available on the WSAA web site

www.wsaa.asn.au

AUTHORISED ITEMS for WATER RETICULATION SYSTEM

Document Update Information

Date	Change Type	Page Number(s)	Details
1 Jul 07	Revision 01	14 – 16 2 3	<ul style="list-style-type: none"> • New Inlet and Outlet riser added • Existing risers moved to Maint Section • Brass Fittings moved to Maint Section PE pipe Pressure Rating min now PN16 Product description and sizes added
15 Jan 2009	Revision 02	General	Standards Unit details changed
		5	AVK Series 16/50 Valves added
4 Feb 2010	Amendment	7	SA Water Stock No amended (Screwed Flange)
12 Dec 2011	Amendment	2	AS 3855 amended to AS 4020

AUTHORISED ITEMS for WATER RETICULATION SYSTEM

Copper Tube

Copper Tube to AS1432 Type A, colour code Green shall be acceptable. Annealed or Bendable grades to suit application. Authorised size range covers 20, 25, 40 and 50mm diameters.

Authorised Manufacturers

- Kembla

Applicable Australian Standards

- AS1432 Copper Tubes for plumbing, gas fitting and drainage applications.

*For more details about these manufacturers refer to the **Manufacturers** section of this manual.*

Brass Fittings

Material shall be Dezincification Resistant (DR) conforming to the requirements of AS 2345, AS 3688 and be suitable for contact with potable water satisfying AS 4020 requirements.

***Brass Fittings are now detailed in the Maintenance Section of this manual.
They are now predominantly maintenance items.***

Applicable Australian Standards

- AS 2345 Dezincification Resistance of Copper Alloys.
- AS 4020 Suitability of plumbing and water distribution systems products for contact with potable water.
- AS 3688 Water supply - Copper and copper alloy body compression and capillary fittings and threaded-end connectors.

AUTHORISED ITEMS for WATER RETICULATION SYSTEM

Polyethylene Pipe

Where indicated in the WSCM, a detectable underground warning tape shall be laid on top of the embedment material and above the polyethylene pipe to allow the pipe to be located in the future.

Pipe Classification (Material and Pressure Rating)

When ordering pipe specify PE80 (Type B) or PE100: -
Minimum - PN 16 for all sizes

Colour

Blue or Black with Blue Stripes

Allowable Pipe Sizes

DN25	- Connections	DN20 & DN25 Meter Services
DN 40	- Connections	DN40 Meter Service
DN63	- Connections	DN50 Meter Service
DN63	- Cul de Sacs	Comparable to DN50 Copper

Jointing

- Mechanical - up to 63mm
- Electrofusion
- Butt Welding - Factory Butt welding only

Authorised Pipe Manufacturers

- Iplex Pipelines
- Vinidex
- PPI Corporation

Applicable Australian Standards

- AS4130 Polyethylene pipes for pressure applications
- AS1460 Fittings for use with polyethylene pipes
- AS2033 Installation of polyethylene pipe systems (For minimum cover refer Water Supply Construction manual)

For more details about these manufacturers refer to the **Manufacturers** section of this manual.

AUTHORISED ITEMS for WATER RETICULATION SYSTEM

PE Fittings - Polyethylene pipe

Combinations of fittings to achieve specifications in the Water Supply Construction Manual are acceptable from the following suppliers:

Mechanical Joints 25 mm – 63 mm

Magnum (IPLEX)
 Milnes (ESSE)
 George Fischer
 Philmac
 Plasson
 Plast (Fusion Plast)

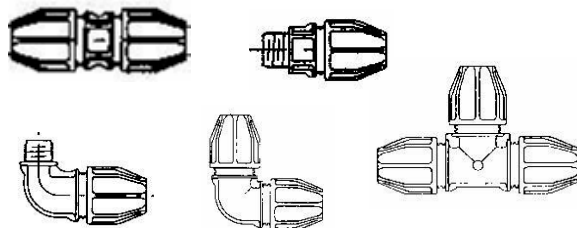

- Tita Coupling (Brass)



Electrofusion Joints 25 mm – 63 mm

Fusamatic (Fusion Plast)
 George Fischer
 Philmac (Durafuse & Friatec)
 Plasson
 Rollmaplast



Standard

Reducing

Also Available

- Tees
- 45 and 90 Bends
- Stub Flanges

Electrofusion Tapping Saddles.

Fusamatic (Fusion Plast)
 George Fischer

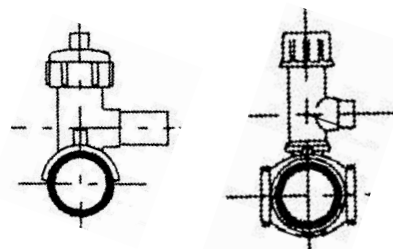

NOTE : PE fittings with male threaded End Connectors shall not be screwed directly into Pre-Tapped Connectors or Tapping saddles. Refer to End Connectors (Autotherm and TITA).

AUTHORISED ITEMS for WATER RETICULATION SYSTEM

SA Water Product Description

***Adaptor - Insulated
 (for Copper Water Connections)***

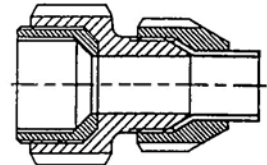

Alternative Description

Size	SA Water Stock No.	Autotherm	RMC
20mm BSP F - 20mm Copper Tube (20 nom Main Cock - 20 Copper Tube)	4730-4924	*	
20mm BSP F - 25mm Copper Tube (20 nom Main Cock - 25 Copper Tube)	4730-4925	*	
50mm BSP F - 50mm BSP M (38 nom Main Cock - Copper Elbows)	4730-4963	*	*

SA Water Product Description

***Adaptor - End Connector
 (for Polyethylene Water Connections)***

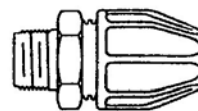

4730-4926

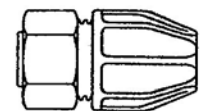

4730-4965

Alternative Description

Adaptor Insulated for Polyethylene

Size	SA Water Stock No.	Autotherm (Philmac)	TITA
20mm BSP M - 25mm Poly Tube	-----		*
20mm BSP M - 25mm Poly Tube	4730-4926	*	
20mm BSP F - 25mm Poly Tube (20 nom Main Cock - 25 Poly Tube)	4730-4965	*	

AUTHORISED ITEMS for WATER RETICULATION SYSTEM

SA Water Product Description

Main Cock

Alternative Description

Cock Plug

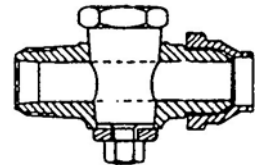

Size Nom. Pipe Tube (mm)	SA Water Stock No.	Autotherm
20	4820-0120	★
40	4820-0133	★

SA Water Product Description

Cock - Boundary Cock

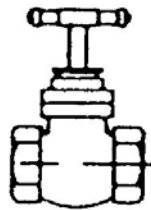

Brass with Screwed
BSP End Connections

Valves with PE
End Connections

Alternative Description

Shower cock

Valve Size	Brass Valves with Screwed BSP End Connections		Valves with PE End Connections		
	Wadhams	Galvin To AS3496	PE Pipe Size	Ductile Iron Iplex AVK Series 03/30	POM Iplex AVK Series 16/50
20			25	★	★
25	★	★	32	★	★
32	★	★	40	★	★
40	★	★	50	★	★
50	★	★	63	★	★

AUTHORISED ITEMS for WATER RETICULATION SYSTEM

SA Water Product Description

Elbow - Copper 90 Degree With Nuts

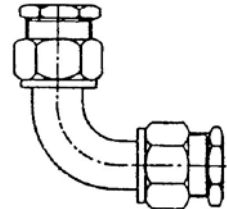

Alternative Description

Item Nominal Tube	SA Water Stock No.	Autotherm
25	4730-1518	*
32	4730-1519	*
40	4730-1520	*
50	4730-1521	*

SA Water Product Description

Elbow - Copper 45 Degree With Nuts

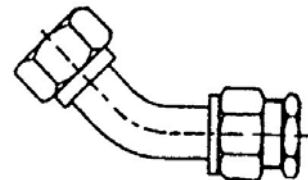

Alternative Description

Item Nominal Tube	SA Water Stock No.	Autotherm
25	4730-1514	*
32	4730-1515	*
40	4730-1516	*
50	4730-1517	*

AUTHORISED ITEMS for WATER RETICULATION SYSTEM

SA Water Product Description

***Loose Ring Joint
for 50mm Water Meter***

Includes Bolts and Gaskets Kit
 FBE Coated (Blue)

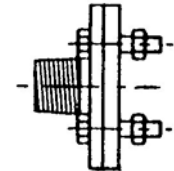

Alternative Description

Loose Ring Joint for 50mm Water Meter

Nom. Size DN	SA Water Stock No.	Autotherm
50	6680-0683	★

SA Water Product Description

***Flange Screwed
for 50mm Water Meter***

Includes Bolts and Gasket Kit
 FBE Coated (Blue)

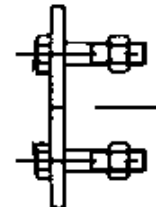

Alternative Description

Screwed Flange for 50mm Water Meter

Nom. Size DN	SA Water Stock No.	Autotherm
50	4730-1224	★

AUTHORISED ITEMS for WATER RETICULATION SYSTEM

SA Water Product Description

Nut Union



Alternative Description

DN Tube	SA Water Stock No.	Autotherm	Wadham
32	4730-1781	★	★
44	4730-4016	★	
50	4730-1783	★	
57	4730-1784	★	

AUTHORISED ITEMS for WATER RETICULATION SYSTEM

SA Water Product Description

***Riser Inlet Assembly for
 20 mm Dual Check Meter
 - With 20 mm Ball Valve
 for PE Water Connections***

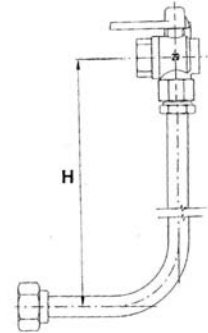

Alternative Description

DN Tube x Height	SA Water Stock No.	Autotherm	Wadhams
20 x 300	4730-1913	★	★
20 x 530	4730-1910	★	★

SA Water Product Description

***Riser Inlet Assembly
 - With Right Angle Valve
 for PE Water Connections***

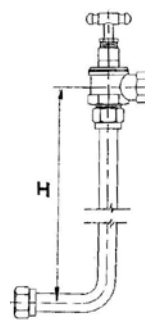

25 mm

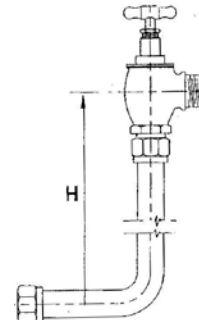

40 & 50 mm

Alternative Description

DN Tube x Height	SA Water Stock No.	Autotherm	Wadhams
25 x 530	4730-1387	★	
40 x 530 *	4730-1400	★	
50 x 530	4730-1403	★	

* Also used for 32 mm meter installation

AUTHORISED ITEMS for WATER RETICULATION SYSTEM

SA Water Product Description

Riser Inlet

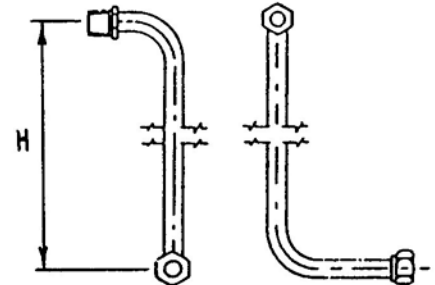

Alternative Description

DN Pipe x Height	SA Water Stock No.	Autotherm	Wadhams
50 x 230	4730-1381	★	
50 x 530	4730-1382	★	

SA Water Product Description

***Riser Outlet for 20 mm
Dual Check Water Meters***

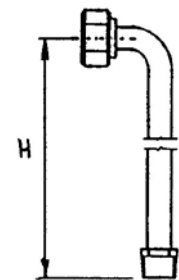

Alternative Description

DN Tube x Height	SA Water Stock No.	Autotherm	Wadhams
20 x 150	4730-5134	★	★
20 x 300	4730-5133	★	★

AUTHORISED ITEMS for WATER RETICULATION SYSTEM

SA Water Product Description

Riser Outlet

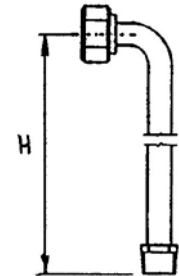

Alternative Description

DN Tube x Height	SA Water Stock No.	Autotherm	Wadhams
25 x 290 mm	4730-1383	★	★
32 x 290 mm	4730-1425	★	
40 x 290 mm	4730-1426	★	

SA Water Product Description

Riser Outlet

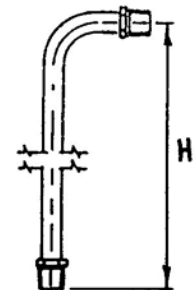

Alternative Description

DN Tube x Height	SA Water Stock No.	Autotherm
50 x 300 mm	4730-1427	★

AUTHORISED ITEMS for WATER RETICULATION SYSTEM

SA Water Product Description

Tailpiece Union - Male BSP

Alternative Description

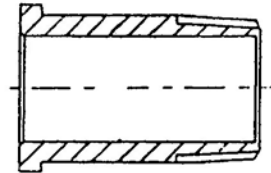

DN Pipe	SA Water Stock No.	Autotherm
25	4730-1768	★

SA Water Product Description

Tailpiece Union - Meter Inlet

Alternative Description

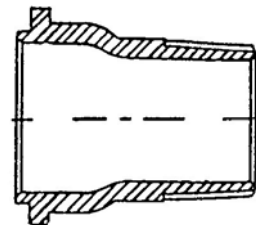

DN Pipe	SA Water Stock No.	Autotherm
32	4730-1748	★
40	4730-1814	★

AUTHORISED ITEMS for WATER RETICULATION SYSTEM

SA Water Product Description

Tailpiece Union - Meter Outlet

Alternative Description

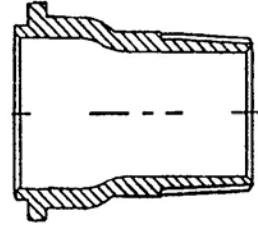

DN Pipe	SA Water Stock No.	Autotherm
32	4730-1747	★
40	4730-1815	★

AUTHORISED ITEMS for WATER RETICULATION SYSTEM

SA Water Product Description

***Pre-Tapped Connectors
(FBE Coated)***

Alternative Description (Product Marking)

***Pre-Tapped Connector
Readytap Connector***

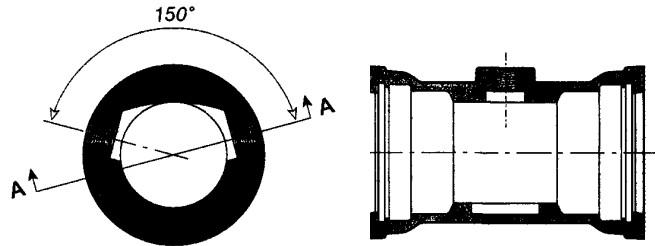

Soc/Soc and Soc/Spig

Note : Soc/Spig only authorised for DICL pipes only

For DICL and PVC Pipes

Size DN Pipe x BSP Tapped Boss	Material	Crevet	Tubemakers Water Ψ	Stockbrands Supertap
100mm x 20mm	DICL	*	*	
100mm x 40mm	DICL	*	*	
150mm x 20mm	DICL	*	*	
150mm x 40mm	DICL	*	*	
100mm x 20mm	Nylon			*

Ψ Also available with twin outlets both sides.

AUTHORISED ITEMS for WATER RETICULATION SYSTEM

Ψ SA Water Product Description

Tapping Saddles

Alternative Description

Tapping Bands

Tapping Collars

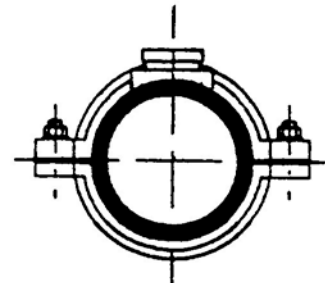

For AC Pipes Only

Tapping Saddles - 20 & 25mm Offtake

Manufacturer / Product Marking	Pipe Size (mm)							Material
	80	100	150	200	250	300	375	
NIBF (Iplex)		*	*	*	*	*	*	Ductile Iron
Milnes / 60B (Iplex)	*	*	*	*	*	*	*	Gunmetal
RMC / Sureseal	*	*	*	*	*	*	*	Gunmetal
Stockbrands Nylon		*	*	*				Includes "Self – Tapper" Type
Tyco Water / Iso-tap		*	*			*		Ductile Iron
Wang / KT Tapping Saddle (Tyco)	*	*	*	*				316 Stainless Steel
Wang / BSP Tapping Clamp (Tyco)					*	*	*	316 Stainless Steel

Tapping Saddles - 40mm Offtake

Manufacturer / Product Marking	Pipe Size (mm)							Material
	80	100	150	200	250	300	375	
Milnes / 60B (Iplex)	*	*	*	*	*	*	*	Bronze
RMC / Sureseal		*	*	*	*	*	*	Bronze
Wang / BSP Tapped Clamp (Tyco)	*	*	*	*	*	*	*	316 Stainless Steel

Tapping Collar-50mm Offtake (50-40 Reducing Bush Required)

Manufacturer / Product Marking	Pipe Size (mm)							Material
	80	100	150	200	250	300	375	
Wang / BSP Tapped Clamp (Tyco)	*	*	*	*	*	*	*	316 Stainless Steel

AUTHORISED ITEMS for WATER RETICULATION SYSTEM

(continued)

SA Water Product Description

Tapping Saddles

For DICL & CICL Pipes Only

Tapping Saddles - 20 & 25mm Offtake

Manufacturer / Product Marking	Pipe Size (mm)								Material
	80	100	125	150	200	250	300	375	
NIBF / Taptite (Iplex)		*		*	*	*	*		Duct. Iron Bit. or FBE Coated
Tyco Water / Iso-tap		*		*			*		Ductile Iron
Wang / KT (Tyco)	*	*	*	*	*				316 Stainless Steel

Tapping Saddles - 40mm Offtake

Manufacturer / Product Marking	Pipe Size (mm)								Material
	100	125	150	200	250	300	375		
NIBF / Taptite (Iplex)	*	*	*	*	*	*	*		Duct. Iron-Bit. or FBE Coated
Tyco Water / Iso-tap			*				*		Ductile Iron
Wang / BSP Tapped Clamp (Tyco)	*	*	*	*	*	*	*	*	316 Stainless Steel

Tapping Collar-50mm Offtake (50-40 Reducing Bush Required)

Manufacturer / Product Marking	Pipe Size (mm)								Material
	100	125	150	200	250	300	375		
NIBF (Iplex)	*	*	*	*	*	*	*		Ductile Iron
Wang / BSP Tapped Clamp (Tyco)	*		*	*	*	*	*	*	316 Stainless Steel

AUTHORISED ITEMS for WATER RETICULATION SYSTEM

(continued)

SA Water Product Description

Tapping Saddles

For PVC Pipes Only (Full Circle Clamping)

Tapping Saddles - 20 & 25mm Offtake

Manufacturer / Product Marking	Pipe Size (mm)						Material
	80	100	150	200	250	300	
NIBF / Taptite (Iplex)		*	*	*	*	*	Duct. Iron FBE Coated
Milnes / 60 A (Iplex)		*	*	*	*		Gunmetal
RMC / Sureseal		*	*	*	*		Gunmetal
Wang / KT (Tyco)	*	*	*	*			316 Stainless Steel
Stockbrands Nylon		*	*	*			Includes "Self – Tapper" Type
Tyco Water / Iso-tap		*	*				Ductile Iron
Talbot / Self tapping		*	*	*			316 Stainless Steel

Tapping Saddles - 40mm Offtake

Manufacturer / Product Marking	Pipe Size (mm)						Material
	80	100	150	200	250	300	
Milnes / 60 A (Iplex)		*	*	*	*		Gunmetal
RMC / Sureseal		*	*	*	*		Gunmetal
Wang / BSP Tapped Clamp	*	*	*	*	*	*	316 Stainless Steel

Tapping Collar - 50mm Offtake (50 - 40 Reducing Bush Required)

Manufacturer / Product Marking	Pipe Size (mm)						Material
	80	100	150	200	250	300	
Milnes / 60 A (Iplex)		*	*	*	*	*	Gunmetal
Wang / BSP Tapped Clamp (Tyco Water)		*	*	*	*	*	316 Stainless Steel

AUTHORISED ITEMS for WATER RETICULATION SYSTEM

(continued)

SA Water Product Description

Tapping Saddles

Alternative Description
Swivel Tapper

Electrofusion Couplings

Tapping Saddles – 20, 25 & 32mm Offtakes (may require a reducer)

Manufacturer / Product Marking	Pipe Size (mm)				Material
	63	110	125	180	
Fusamatic (Fusion Plast)	*	*	*	*	PE80 / PE100
George Fischer	*	*	*	*	PE80 / PE100
Plasson	*	*	*	*	Cat # 9630 PE80 / PE100 with 316 Stainless Steel Bolts & nuts

Mechanical Couplings

For 63 mm PE pipe only

Tapping Saddles - 20 & 25mm Offtakes

Manufacturer / Product Marking	Pipe Size (mm)				Material
	63				
Plasson		*			Cat # 6530 range Polypropylene with 316 Stainless Steel Bolts & nuts
Talbot Self Tapping		*			Polypropylene

Rev 1
Jul 07

AUTHORISED ITEMS for WATER RETICULATION SYSTEM

SA Water Product Description

***No. 2 Meter Access
(Cast Iron)***

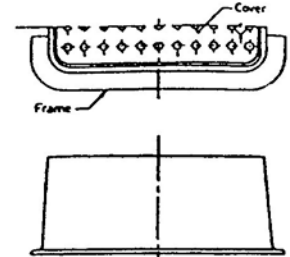

Alternative Description

No. 2 Meter Box

Item	SA Water Stock No.	BIA (PCP)
Frame	5680-0034	*
Cover	5680-0030	*
Assembly	5680-1501	

SA Water Product Description

***No. 3 Meter Access
(Cast Iron)***

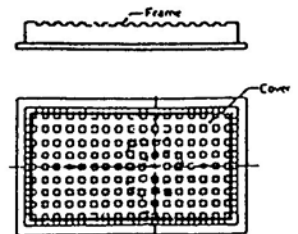

Alternative Description

No. 3 Meter Box

Item	SA Water Stock No.	BIA (PCP)
Frame	5680-0035	*
Cover	5680-0031	*

AUTHORISED ITEMS for WATER RETICULATION SYSTEM

SA Water Product Description

***No. 4 Meter Access
(Cast Iron)***

Alternative Description

No. 4 Meter Box

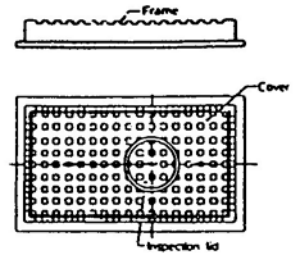

Item	SA Water Stock No.	BIA (PCP)
Frame	5680-0036	*
Cover	5680-0032	*
Lid	5680-0038	*

SA Water Product Description

***No. 5 Meter Access
(Cast Iron)***

Alternative Description

No. 5. Meter Box

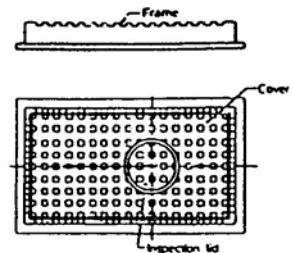

Item	SA Water Stock No.	BIA (PCP)
Frame	5680-0037	*
Cover	5680-0033	*
Lid	5680-0039	*

AUTHORISED ITEMS for WATER RETICULATION SYSTEM

SA Water Product Description

20mm Meter Manifold

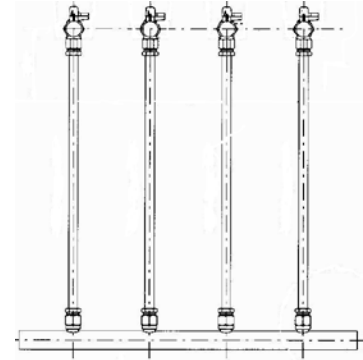

Alternative Description

Item		SA Water Stock No.	Autotherm
No. of Risers	Connector Pipe Size (mm)		
2	25	4730-0089	★
3	25	4730-0092	★
3	40	4730-0090	★
4	40	4730-0091	★
5	40	4730-0093	★
6	40	4730-0094	★

Notes

- Up to 12 x 20 mm services may be connected to a 40 mm water service by coupling manifolds together (40 mm connector pipe only).

AUTHORISED ITEMS for WATER RETICULATION SYSTEM

INDEX

Access Cover

No. 2 Meter	19
No. 3 Meter	19
No. 4 Meter	20
No. 5 Meter	20

Adaptor

End Connector.....	4
Insulated	4

Cock

Boundary Cock BSP ends	5
Boundary Cock PE ends.....	5

Copper Tube

Standard	1
----------------	---

Elbow

Copper 45 degree w/nuts.....	6
Copper 90 degree w/nuts.....	6

Flange Screwed

for 50mm Water Meter.....	7
---------------------------	---

Loose Ring Joint

for 50mm Water Meter.....	7
---------------------------	---

Main Cock

.....	5
-------	---

Meter Manifold

-20mm	21
-------------	----

Nut Union

.....	8
-------	---

PE Fittings

for Polyethylene pipe	3
-----------------------------	---

Polyethylene Pipe

Standard	2
----------------	---

Pre-Tapped Connectors

.....	14
-------	----

Riser

Inlet	10
Inlet Assembly 20mm with Ball Valve.....	9
Inlet Assembly with Right Angle Valve.....	9
Outlet.....	11
Outlet for 20mm Dual Check Meter.....	10

Tailpiece Union

Male BSP	12
Meter Inlet.....	12
Meter Outlet	13

Tapping Saddles

63mm PE Pipe.....	18
AC Pipes	15
DICL & CICL Pipes.....	16
PVC Pipe.....	17