

Radiator Repairers Trade Waste Guideline No. 2

INTRODUCTION

Trade waste discharges from companies conducting radiator repair have the potential to adversely affect the sewerage system. Coolants and waste waters can contain contaminants such as heavy metals, grease/oil and suspended solids and have a low pH. Appropriate management practices at each site are therefore necessary.

For the purpose of this Guideline 'Radiator Repairer' refers to the draining, cleaning, repairing and testing of industrial and automotive radiators. 'Coolants' refers to water and water based fluids used in radiators.

KEY TRADE WASTE QUALITY REQUIREMENTS

PARAMETER	GENERALLY ACCEPTED LEVEL
Suspended Solids	<500 mg/L average
Grease/Oil	<100 mg/L
pH	Between 6-10 units
Zinc, Copper, Lead	<10mg/L
Tin	<50mg/L
Total Dissolved Solids	<1500mg/L
Flow rate to sewer	Dependant on capacity of receiving sewer

Note: Discharge limits may be varied under certain circumstances for individual dischargers.

DESIGN / INSTALLATION

- Only waste water complying with [SA Water's Standards of Acceptance of Liquid Wastes to Sewer](#) is permitted to discharge to sewer.
- All waste waters, oils, solvents, settled sludges and chemical solutions not permitted to discharge to sewer are stored in approved containers or tanks prior to removal by a licensed liquid waste contractor in accordance with the [Trade Waste Blind Tank Guideline No. 3](#)
- All radiator repair areas, pre-treatment systems and chemical storage areas are bunded in accordance with [Trade Waste Bunding Guideline No. 4](#).
- Where waste water contaminants exceed the Standards of Acceptance, one of the following options is employed:
 - **Option 1** – Isolation from the sewer with subsequent removal of all waste water by a licensed liquid waste contractor. A recirculation system with alkali dosing and solids removal will extend the life of process waters prior to removal offsite. See Figure 1.
 - **Option 2** – Batch discharge to sewer via an approved pre-treatment system. This may include a coalescing plate separator, pH adjustment and metal precipitation. A pH electrode with 'set points' is linked to the pump control to safeguard against incorrect disposal. See [Trade Waste Batch Treatment Guideline No. 17](#).
 - **Options 3** – Continuous discharge to sewer via an approved pre-treatment system. Similar in principle to Option 2, however an automatic system controls alkali dosing and safeguards the sewer. See Figure 2.

Revised January 2011

Further information

(08) 7424 1336

www.sawater.com.au

tradewastebranch@sawater.com.au

- All waste waters from radiator repair operations (using Options 2 or 3) discharge to a gully trap that does not accept other waste water streams. Samples for monitoring purposes are drawn from this point.

BEST PRACTICE MANAGEMENT ASPECTS

- Minimise use of soldering flux solution to reduce zinc levels (flux contains approximately 400,000mg/L zinc).
- Grit blasting to clean components instead of acid pickling.

TYPICAL PRETREATMENT

- Coalescing plate separator.
- pH adjustment for metal precipitation.
- Settling pit/ tank

MAINTENANCE

- It is the responsibility of site management to ensure the effective operation of all pre-treatment equipment. e.g. Ongoing removal of accumulated oil and/or coolant, sludge removal, treatment chemical replacement and pH probe calibration and maintenance.

ADDITIONAL INFORMATION

Mains Water Protection (AS/NZS3500-2003 Part 1), [Trade Waste General Policy](#),

Revised January 2011

Further information

(08) 7424 1336

www.sawater.com.au

tradewastebranch@sawater.com.au

Figure 1: RECIRCULATING WASTEWATER SYSTEM

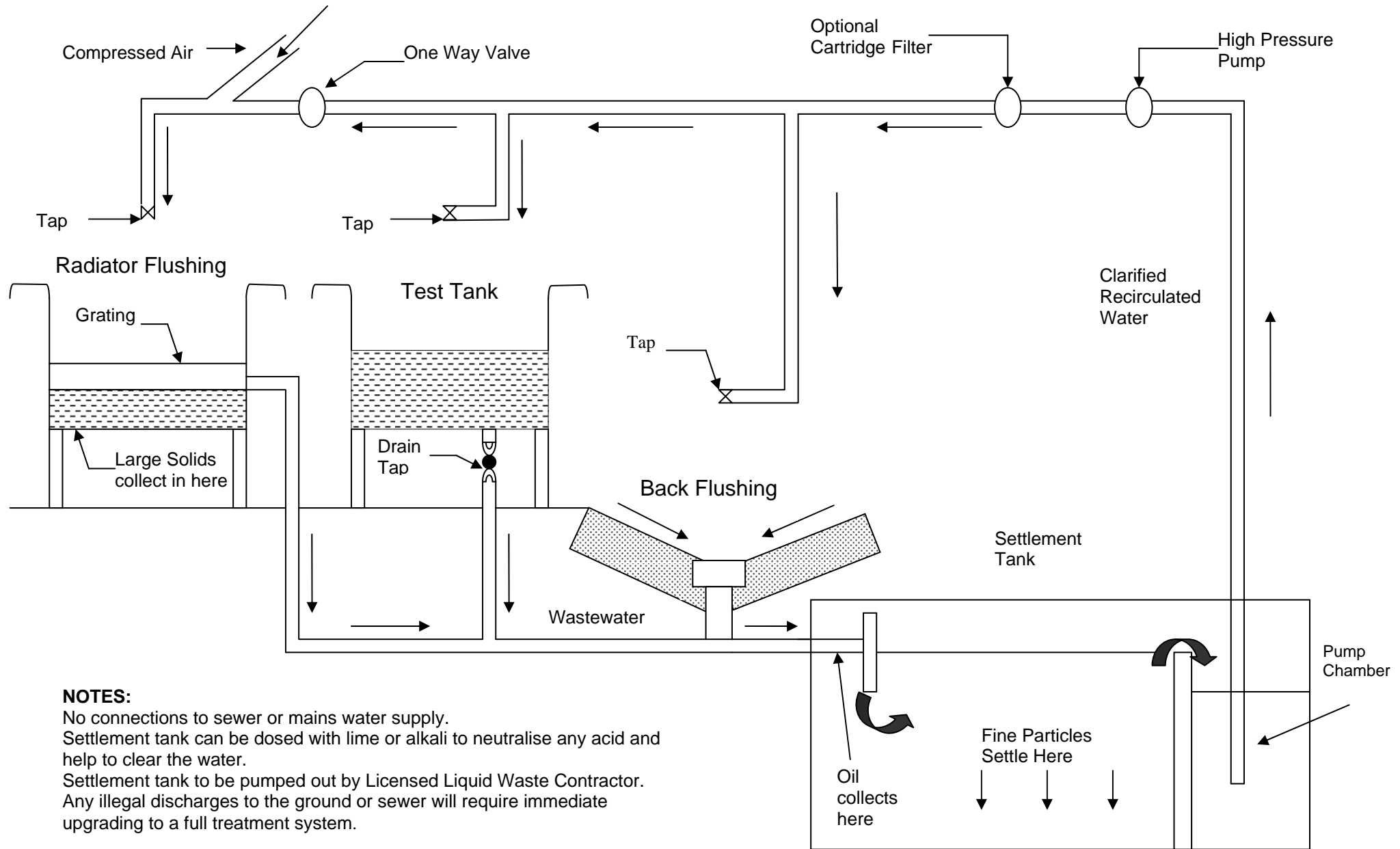

NOTES:

- No connections to sewer or mains water supply.
- Settlement tank can be dosed with lime or alkali to neutralise any acid and help to clear the water.
- Settlement tank to be pumped out by Licensed Liquid Waste Contractor.
- Any illegal discharges to the ground or sewer will require immediate upgrading to a full treatment system.

Figure 2: CONTINUOUS DISCHARGE PRETREATMENT SYSTEM

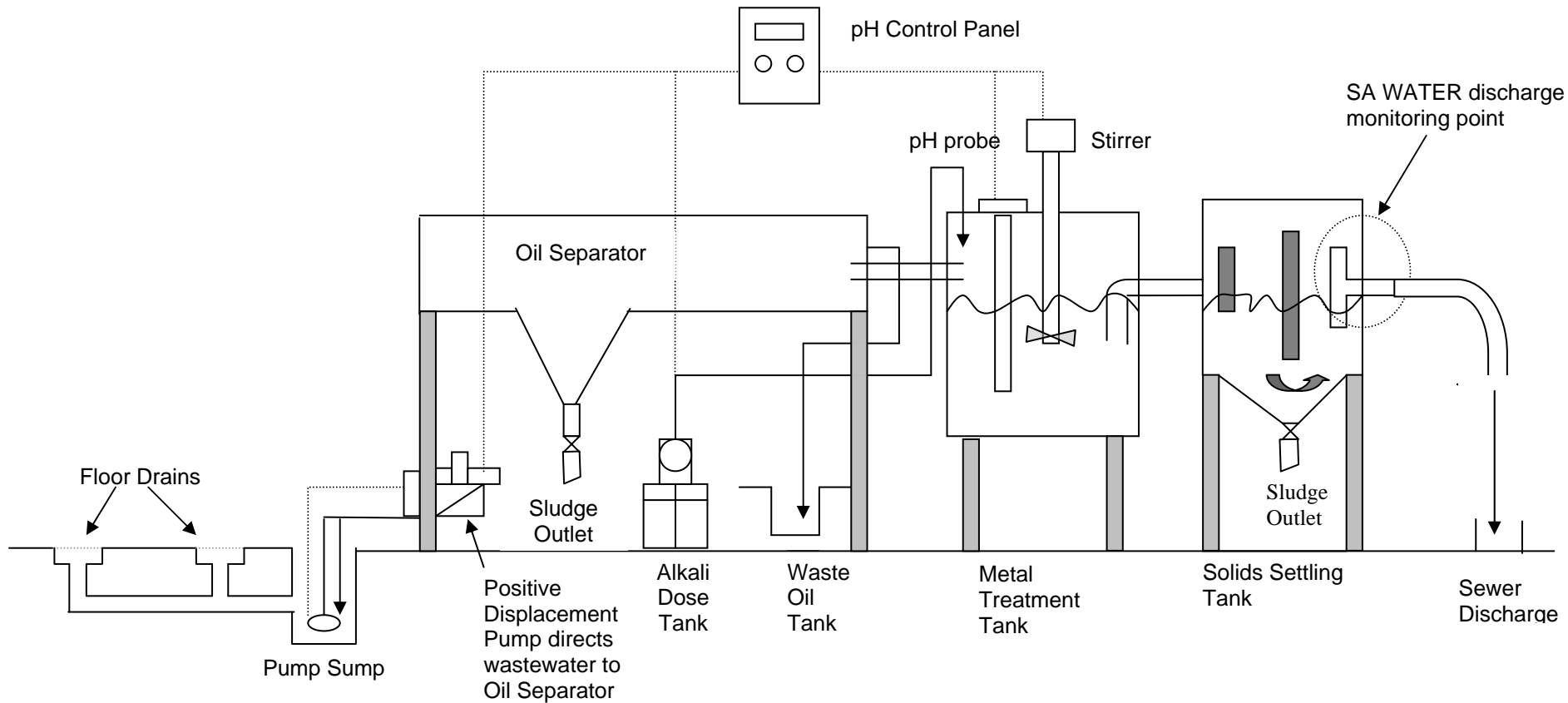

NOTES:

- The treatment systems illustrated on this plan are intended as a guide only.
- pH probes must be checked and calibrated regularly.
- All controls must be correctly maintained.
- Dosing tanks must be replenished when necessary.
- Discharge via pH controlled and TIMED DELAY PUMP or VALVE to SEWER.
- This drawing is not to scale.