



Engineering

Technical Standard

TS 0502 – Authorised Products – Gravity Sewer and Pressure Pumping Main Systems

Version: 6.0

Date: 15 March 2022

Status: Final

Document ID: SAWS-ENG-0502

© 2022 SA Water Corporation. All rights reserved. This document may contain confidential information of SA Water Corporation. Disclosure or dissemination to unauthorised individuals is strictly prohibited. Uncontrolled when printed or downloaded.



**Government of
South Australia**

Copyright

This Standard is an intellectual property of the South Australian Water Corporation. It is copyright and all rights are reserved by SA Water. No part may be reproduced, copied or transmitted in any form or by any means without the express written permission of SA Water.

The information contained in this Standard is strictly for the private use of the intended recipient in relation to works or projects of SA Water.

This Standard has been prepared for SA Water's own internal use and SA Water makes no representation as to the quality, accuracy or suitability of the information for any other purpose.

Application & Interpretation of this Document

It is the responsibility of the users of this Standard to ensure that the application of information is appropriate and that any designs based on this Standard are fit for SA Water's purposes and comply with all relevant Australian Standards, Acts and regulations.

Users of this Standard accept sole responsibility for interpretation and use of the information contained in this Standard. Users should independently verify the accuracy, fitness for purpose and application of information contained in this Standard.

Only the current revision of this Standard should be used which is available for download from the SA Water website.

Significant/Major Changes Incorporated in This Edition

This Revision updates the October 2021 edition (5.1) of TS 0502 Authorised Products – Gravity and Pressure Main Sewer Systems. Changes from Revision 5.1 include:

Clauses 1

Introduction text updated.

Clauses 1.1

Purpose text updated.

Clause 1.2

Glossary updated with WSCM.

Clause 2.1

Safety in Design requirements added.

Clause 3.1.1

Reference to PIPA document POP 101 added and reference for fittings authorised for use, with U PVC pipe.

Clause 3.1.4

Manufacturer name change – **Civilmart**.

Clause 3.1.6

New manufacturer and products added. **Viadux** TYTON X Range.

Clause 3.2.1.1

New manufacturer and product added. **Plastec** reinforced drop bends.

Clause 3.2.1.2

New manufacturer added. **Plastec** standard drop bends.

Clause 3.3.1

Standards list updated.

Clause 3.3.1.1

Manufacturer name change – **Civilmart**.

Clause 3.3.1.2

Manufacturer name change – **Civilmart**.

Clause 3.3.1.3

Manufacturer name change – **Civilmart**.

Clause 3.3.1.4

Manufacturer name change – **Civilmart**.

Clauses 3.3.1.5

Standards list updated.

Clauses 3.3.1.5 – 3.3.1.10

New manufacturer and products added. **Iplex** EZipit 1000 Polypropylene Maintenance Holes.

Clause 3.3.2.2

New manufacturer and products added. **Iplex** Maintenance shafts with swivel joints.

Clause 4.5.1

Image updated.

Clause 4.5.2

New Clause for Tapping Saddles - Low Pressure to Gravity Sewer

Clause 5.1.1

New manufacturer and products added. **Ducast** - Class D and E rated covers. New information added, in line with AS/NZS 3996 (2019), use of Class E rated covers.

Clause 5.1.1.1

Manufacturer name change – **Civilmart**.

Clause 5.1.1.2

New manufacturer and products added. **Ducast**. Manufacturer name change – **Civilmart**.

Clause 5.3.1 and 5.4.1

Updated images and information added on hardness rating of timber bearers. Manufacturer name change – **Civilmart**.

Clause 6.1

Manufacturer name change – **Ferretti International**.



Document Controls

Revision History

Revision	Date	Author	Comments
1.0	08 April 2016	R Pearce	First TS Release – superseding the November 2014 edition of Authorised Items for Sewer Systems.
2.0	20 March 2017	R Pearce	Numerous Clauses added/altered/updated, refer P. 2 - 4.
3.0	25 October 2017	R Pearce	Clause 3.1.1 – U PVC pipe SN rating changed.
4.0	22 February 2019	R Pearce	Numerous Clauses added/ altered/ updated – refer P. 2.
5.0	25 June 2020	KT Claridge	Numerous Clauses added/ altered/ updated – refer P. 2.
5.1	27 October 2021	KT Claridge	Numerous Clauses added/ altered/ updated – refer P. 2.
6.0	15 March 2022	KT Claridge	Numerous Clauses added/ altered/ updated – refer P. 2.

Template: Technical Standard Version 6.00, 10/05/2016

Approvers

Role	Signature and Date
Responsible Discipline Lead Kevin Claridge	28/03/2022 X  ----- Signer's Name Signed by: CL001730
Manager Engineering Quality and Innovation Matthew Davis	28/03/2022 X  ----- Signer's Name Signed by: DA003681
Senior Manager Engineering Services Richard Gray	28/03/2022 X  ----- Signer's Name Signed by: GR001964

Reviewers

Role	Name	Revision	Review Date
Principal Engineer, Reticulation Networks	T Galek	4.00	1 March 2019

Contents

1	Introduction.....	7
1.1	Purpose	7
1.2	Glossary	7
1.3	References	8
1.3.1	Australian and International.....	8
1.3.2	SA Water Documents.....	9
1.4	Definitions	9
1.5	Disclaimer	10
2	Scope	11
2.1	Safety in Design.....	11
3	Non-Pressure (Gravity) Sewer.....	12
3.1	Pipes.....	12
3.1.1	Unplasticized Polyvinyl Chloride (U PVC), (DWV)	12
3.1.2	Polypropylene Pipe (Structured Wall) (PP)	12
3.1.3	Glass Filament Reinforced Thermosetting Plastic (GRP).....	13
3.1.4	Reinforced Concrete Pipe	13
3.1.5	Mild Steel Polyurethane Lined Pipe (MSPL)	13
3.1.6	Ductile Iron Pipe (DI)	14

3.1.7	Polyethylene Pipe.....	14
3.2	Fittings	15
3.2.1	U PVC (DWV)	15
3.2.1.1	Reinforced Fittings	16
3.2.1.2	Standard Fittings	17
3.2.1.2	Standard Fittings (Cont'd).....	18
3.2.1.3	Flexible Fittings.....	18
3.2.2	Polypropylene (Structured Wall) (PP).....	19
3.3	Maintenance Structures.....	20
3.3.1	Precast Concrete Maintenance Holes.....	20
3.3.1.1	Concrete Shaft Increments.....	21
3.3.1.2	Concrete Conversion Slabs	21
3.3.1.3	Concrete Adjustment Rings/Cover Slab.....	22
3.3.1.4	Concrete Base	22
3.3.1.5	Plastic Maintenance Holes.....	23
3.3.1.6	Bearing/Support Ring	24
3.3.1.7	Cone	24
3.3.1.8	Chamber Riser Rings.....	24
3.3.1.9	Standard Bases	25
3.3.1.10	Riser Connection – for PVC and PP	25
3.3.2	Maintenance Shafts.....	25
3.3.2.1	U PVC Shaft Bases.....	27
3.3.2.2	Polypropylene Rubber Ring Shaft Bases	28
3.3.2.3	Polyethylene Shaft Bases.....	29
3.3.2.4	Riser Shaft (U PVC)	29
3.3.2.5	Bends	30
3.3.2.5.1	Vario Bends (U PVC).....	30
3.3.2.5.2	Polypropylene Bends	30
3.3.3	Inspection Opening/Inspection Point.....	31
3.3.3.1	Inspection Opening.....	31
3.3.3.1.1	U PVC Pipes & Fittings	31
3.3.3.2	Inspection Point	31
3.3.3.2.1	U PVC Pipes & Fittings	31
4	Pressure Pumping Main.....	32
4.1	Pipes.....	32
4.1.1	Oriented PVC (O PVC) & Modified PVC (M PVC)	32
4.1.2	Polyethylene Pipe.....	32
4.1.3	Mild Steel Polyurethane Lined Pipe.....	33
4.1.4	Ductile Iron Pipe (DI)	33
4.2	Fittings	34
4.2.1	Ductile Iron (FBE Coated)	34
4.2.2	Polyethylene Fittings.....	38
4.2.2.1	Flange / Flange with Thrust Ring & 80 Flange Fire Plug Offtake	38
4.2.2.2	Electrofusion Couplings	39

4.2.2.3	Electrofusion Puddle Flange	39
4.2.2.4	Butt Weld Fittings	40
4.3	Miscellaneous Fittings	40
4.3.1	Camlock Couplings	40
4.4	Mains Couplings	41
4.4.1	Multi Fit Couplings.....	41
4.4.1.1	Straight, Stepped & Adaptor Flange Couplings	41
4.4.1.2	Gibaults.....	41
4.5	Mains Tapping Fittings	42
4.5.1	Ductile Iron (FBE Coated) Pre-Tapped Connectors	42
4.5.2	Tapping Saddles - Low Pressure to Gravity Sewer	42
4.5.3	Resilient Seat Gate Valve Double Flange	42
4.5.4	Swing Check.....	43
4.5.5	Fire Hydrant (For Air Bleed)	43
4.5.6	Main Cock (For Air Bleed).....	43
5	Covers	44
5.1	Maintenance Hole.....	44
5.1.1	Cast Iron Cover & Frame	44
5.1.1.1	Trafficable.....	44
5.1.1.2	Non Trafficable.....	45
5.2	Maintenance Shaft.....	46
5.2.1	Cast Iron Cover & Frame	46
5.3	Inspection Opening.....	46
5.3.1	Cover & Support Items (Top Stones)	46
5.4	Inspection Point.....	47
5.4.1	Cover and Support Items (Top Stones).....	47
5.5	Street Box / Heavy Duty (Type A)	48
5.5.1	Chamber, Lid and Concrete Support Spacer	48
6	Signs and Tape	49
6.1	Signs	49
6.2	Underground Warning Tape	49

1 Introduction

SA Water is responsible for operation and maintenance of an extensive amount of engineering infrastructure.

This standard has been developed to assist in the design, maintenance, construction, and management of this infrastructure. This Document lists technically conforming products approved for installation within SA Water's infrastructure networks.

The products listed have been approved after their evaluation based upon the SA Water product appraisal procedure.

Approved products shall only be obtained from the listed manufacturer or their authorised agent.

1.1 Purpose

The purpose of this standard is to detail minimum requirements to ensure that assets covered by the scope of this standard are constructed and maintained to consistent standards and attain the required asset life.

This document provides confirmation of products SA Water has authorised, based on their technical merits. Design Consultants and Construction Contractors should use the information presented within this document for confirmation of products SA Water has authorised for use.

Product Manufacturers, suppliers and other stakeholders may also use the information as reference material.

SA Water personnel should source items from the Store. If not stocked, they should procure by means of:

- utilising the relevant SA Water Period Contract or Standing Offer Arrangement,
- where an item is not covered under a Contract or Standing Offer Arrangement, contacting a relevant Stores or Procurement Officer.

1.2 Glossary

The following glossary items are used in this document:

Term	Description
DIPL	Ductile Iron Polyurethane Lined Pipe
DN	Diameter Nominal
DWV	Drain, Waste, Vent
FBE	Fusion Bonded Epoxy
GRP	Glass Filament Reinforced Thermosetting Plastic
MSPL	Mild Steel Polyurethane Lined Pipe
PE	Polyethylene Pipe
PIPA	Plastic Industry Pipe Association
PP	Polypropylene Pipe
PVC	Polyvinyl Chloride
PVC M	Modified PVC
PVC O	Oriented PVC

RRJ	Rubber Ring Joint
SA Water	South Australian Water Corporation
SCL	Steel Cement Lined Pipe
TG	SA Water Technical Guideline
TS	SA Water Technical Standard
U PVC	Unplasticized Polyvinyl Chloride
WSCM	Water Supply Construction Manual

1.3 References

1.3.1 Australian and International

The following table identifies Australian and International standards and other similar documents referenced in this document:

Number	Title
AS 1281	Cement mortar lining of steel pipes and fittings
AS 1302	Steel reinforcing bars for concrete
AS 1303	Steel reinforcing wire for concrete
AS 1304	Welded wire reinforcing
AS 1379	The specification and manufacture of concrete
AS 1579	Arc-welded steel pipes and fittings for water and wastewater
AS 2419.2	Fire Hydrant Valves
AS 2758.1	Aggregates and rock for engineering purposes - concrete aggregates
AS 3571	Glass filament reinforced thermosetting plastics (GRP) pipes - polyester based - Water supply, sewerage and drainage applications
AS 3600	Concrete structures
AS 3735	Concrete structures for retaining liquids
AS 3972	General purpose and blended cements
AS 3996	Access covers and grates
AS 4198	Precast concrete access chambers for sewerage applications
AS 4321	Fusion - bonded medium density polyethylene coating and lining for pipes and fittings
AS 4794	Non-return valves - Swing check and tilting disc
AS/NZS 1260	PVC pipes and fittings for drain, waste and vent (DWV) applications
AS/NZS 2032	Code of practice for the installation of PVC pipe systems
AS/NZS 2280	Ductile iron pipes and fittings
AS/NZS 2638-2	Gate valves for water works purposes
AS/NZS 2648.1	Underground marking tape - non-detectable tape
AS/NZS 3725	Design for installation of buried concrete pipes
AS/NZS 4058	Precast concrete pipes (pressure and non-pressure)
AS/NZS 4129	Fittings for polyethylene pipe for pressure applications
AS/NZS 4130	Polyethylene (PE) pipes for pressure applications

AS/NZS 4158	Thermal-bonded polymeric coatings on valves and fittings for water industry purposes
AS/NZS 4441	Oriented PVC (PVC-O) pipes for pressure applications
AS/NZS 4765	Modified PVC (PVC-M) pipes for pressure applications
AS/NZS 4999	PVC - U maintenance shafts
AS/NZS 5065	Polyethylene and polypropylene pipes and fittings for drainage and sewerage applications
WSA 100 - 2002	Industry standard for PVC - U Maintenance shafts
WSA 137	Water Industry Standard for Maintenance Shafts and Chambers for Sewerage
WSA PS 260	Gate valves - resilient seated
WSA PS 264	Non-return (reflux) valves
WSA PS 270	Mechanical couplings, unrestrained
WSA PS 318	Marking tape, detectable
WSA PS 319	Marking tape, non-detectable

1.3.2 SA Water Documents

The following table identifies the SA Water standards and other similar documents referenced in this document:

Number	Title
TS 0101	Safety in Design
TS 0503	Authorised Products for Water Systems
TS 0710	Concrete

1.4 Definitions

The following definitions are applicable to this document:

Term	Description
SA Water's Representative	<p>The SA Water representative with delegated authority under a Contract or engagement, including (as applicable):</p> <ul style="list-style-type: none"> • Superintendent's Representative (e.g. AS 4300 & AS 2124 etc.) • SA Water Project Manager • SA Water Construction Technical Officer/Manager • Reticulation Networks Wastewater/Water Specialist <p>SA Water nominated contact person</p>
Responsible Discipline Lead	The engineering discipline expert responsible for TS 0502 defined on page 3 (via SA Water's Representative)
Constructor	The organisation responsible for constructing and installing infrastructure for SA Water whether it be a third party under contract to SA Water or an in-house entity.
Designer	The organisation responsible for designing infrastructure for SA Water whether it be a third party under contract to SA Water or a Constructor, or an in-house entity

1.5 Disclaimer

- SA Water reserves the right to alter, amend or withdraw this document, at any time, without prior notice.
- SA Water does not give preference to any particular make or type of product listed herein. Manufacturers are presented in alphabetical order, not in any order of preference.
- All products listed may be subject to change by the manufacturer. In such circumstances manufacturers are required to notify SA Water of any changes in the design, materials or manufacturing process of any approved product. SA Water is reliant upon manufacturers providing such notification in a timely manner and takes no responsibility for any issue that may arise should a manufacturer fail to do so.
- It is the responsibility of the Designer/ Constructor to ensure selected products are appropriate for the intended application.
- It is the responsibility of the Designer/ Constructor to ensure the product complies with the infrastructure category and meets the relevant Australian standards.
- It is the responsibility of the Constructor to ensure components do not exceed any expiry date.
- Product sizing may vary between manufacturers. Size range provided herein is a guide only and the Designer/ Constructor shall refer to the manufacturer for the product size and availability.
- Pipe and fitting sizing have been limited to DN 300 throughout this document. Larger sizes are available from the manufacturer. However, consideration of any product not itemised herein is subject to SA Water approval.
- Information within this document is correct at time of publication E&OE. The date of publication of this document can be found on the front page, and, in the left-hand corner of the footer on each subsequent page.

2 Scope

This document specifies products that are authorised for use in the following sewer systems:

- Gravity Sewer Systems up to a maximum size of DN 300.
- Pressure Pumping Mains up to a maximum size of DN 200.

Should a development project contain any product of diameter larger than stated above, specific approval from SA Water will be required for the works to be undertaken by means of the Developer Agreement.

The developer's Consultant or Contractor shall provide the SA Water Representative with data sheets/ manufacturer information for all products larger than stated above.

SA Water will review the information provided and advice regarding the suitability of the product.

2.1 Safety in Design

SA Water is committed providing safe workplaces for our people and safe services for our customers.

In keeping with this commitment, and to ensure the Supplier/Manufacturer has satisfied their legislated duties, the Supplier/Manufacturer shall provide information in accordance with the Work Health and Safety Act 2012 (SA) part 2 division 3, section 25. This may take the form of Operation and Maintenance manuals and/or SiD Hazard Registers (as specified by TS 0101).

Designers that utilise products contained in this Standard shall apply SA Water Technical Standard TS 0101 to incorporate the information provided by the Supplier/Manufacturer in the development of their design/s and transfer this to relevant parties.

3 Non-Pressure (Gravity) Sewer

3.1 Pipes

3.1.1 Unplasticized Polyvinyl Chloride (U PVC), (DWV)

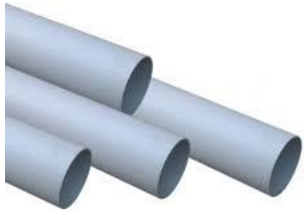
Shall comply with the following Standard	AS/NZS 1260 AS/NZS 2032	 <p>DN 100 - 300</p>
Notes	<p>DN 100 = SN 10 DN 150 - 300 = SN 8</p> <p>Solvent weld pipes only</p> <p>Refer to Clause 3.2 for fittings authorised for use with U PVC pipe. Other products may be considered for a specific installation. For such circumstance, specific approval is required from the SA Water Representative.</p> <p>Construction of DWV pipes and fitting, shall be undertaken in compliance with PIPA document POP 102 (Solvent Cement Welding of PVC Pipe)</p>	
Manufacturers	<p style="text-align: center;">Iplex Pipelines</p> <hr/> <p style="text-align: center;">Pipe King</p> <hr/> <p style="text-align: center;">Pipemakers</p> <hr/> <p style="text-align: center;">Viadux</p> <hr/> <p style="text-align: center;">Vinindex</p>	

3.1.2 Polypropylene Pipe (Structured Wall) (PP)

Shall comply with the following Standard	AS/NZS 5065	 <p>DN 150 - 300</p>
Notes	<p>SN 10</p> <p>One rubber ring per joint is required – placed in the first or second trough nearest the leading edge of the pipe spigot (refer manufacturer's requirements)</p> <p>Where two or more consecutive ribs are broken, the section of damaged pipe shall be replaced</p> <p>All cuts in Polypropylene structured wall pipe are to be made in the centre of two consecutive ribs</p> <p>All fittings shall be obtained from the same pipe manufacturer</p>	
Manufacturers	<p style="text-align: center;">Iplex</p> <p style="text-align: right;">SewerMAX</p> <hr/> <p style="text-align: center;">Vinindex</p> <p style="text-align: right;">SewerPRO</p>	

3.1.3 Glass Filament Reinforced Thermosetting Plastic (GRP)

Shall comply with the following Standard	AS 3571	
Notes	<p>Use of GRP pipe shall be approved by the SA Water representative.</p> <p>Generally, RRJ (Rubber Ring Joint) pipe used.</p> <p>Fittings shall be obtained from the same pipe Manufacturer.</p>	
Manufacturers	Fibrelogic	Flowtite

DN 150 - 300

3.1.4 Reinforced Concrete Pipe

Shall comply with the following Standard	AS/NZS 3725 AS 3735 AS/NZS 4058	
Notes	Concrete for pipe manufacture shall be calcareous aggregate only.	
Manufacturers	CSR Humes	
	Civilmart	

DN 150 - 300

3.1.5 Mild Steel Polyurethane Lined Pipe (MSPL)

Shall comply with the following Standard	AS 1579 AS 4321	
Notes	Use of MSPL pipe shall be approved by the SA Water representative.	
Manufacturers	Viadux	

DN 300

3.1.6 Ductile Iron Pipe (DI)

Shall Comply with the following Standard	AS/NZS 2280 AS 3680 AS 3681	 <p>DN 300</p>
Notes	Use of DI external coated pipe shall be approved by the SA Water representative. Polyethylene sleeving shall be used with these pipes for corrosion protection, (coloured CREAM).	
Manufacturers	Von Roll (Polyurethane Lined)	Ecopur
	St Gobain PAM (Calcium Aluminate Lined)	TYTON Integral
	Viadux (Sulphate resisting cement mortar)	TYTON X Range

3.1.7 Polyethylene Pipe

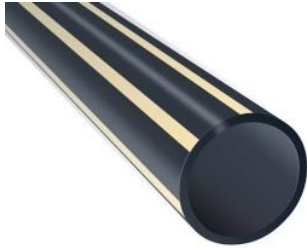
Shall Comply with the following Standard	AS/NZS 4130 AS/NZS 2032	 <p>OD 125 - 250</p>
Notes	Approval for use of PE for a gravity system shall be sought from the SA Water representative. PE100 and PN 16 minimum All pipes shall be coloured: BLACK with CREAM stripes or All CREAM. PE fittings – refer Clause 4.2.2. PE fittings, e.g. connection to U PVC fittings, shall be confirmed and approved by the SA Water representative.	
Manufacturers	Australian Custom Pipes	
	Cromford Pipe	Identipipe
	David Moss Group	
	DM Plastic	Goldline
	Enviropipe	ENVIROPRESSURE
	Iplex Pipelines	POLiplex
	Vinidex	

Size of PE Pipe Equivalent

Standard Pipe Size	PE Pipe Equivalent
DN 100	OD 125
DN 150	OD 180
DN 225	OD 250



Note: Diameters larger than OD 250 require specific SA Water approval.



3.2 Fittings

3.2.1 U PVC (DWV)

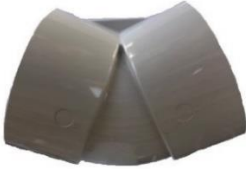
Shall Comply with the following Standard	AS/NZS 1260 AS/NZS 2032
Notes	<p>Only solvent weld joint fittings authorised for use.</p> <p>All Fittings shall be compliant with AS/NZS 1260</p> <p>Standard Fittings are generally rated SN 6.</p> <p>Reinforced Fittings have been strengthened.</p> <p>All Reinforced Fittings shall be approved by SA Water.</p> <p>Suitable techniques for reinforcement may be either:</p> <ul style="list-style-type: none"> a) an injection moulded fitting manufactured with an increased wall thickness, or, b) a standard fitting which has been enhanced by the application of layers of fibreglass wrapping and bracing. <p>For each category refer Manufacturer regarding availability.</p> <p>Refer SCM for approved use of each category.</p>

3.2.1.1 Reinforced Fittings





Plain Bend (F-F) 	Plain Bend (F-F, M-F) 	Angled Junction (F-F, M-F) 	Reducing Junction (F-F, M-F) 
DN 100 & 150 90°	DN 100 & 150 45°	DN 100 & 150 45°	DN 150/150/100 45°
Manufacturers			
Plastec	Plastec	Plastec	Plastec
Holman	Holman	Holman	Holman



Inspection Tee 	Eccentric Taper 		
DN 100 & 150 90°	DN 150 x 100	DN 100 & 150 Drop Bend	
Manufacturers			
Plastec	Plastec	Plastec	
Holman	Holman		

Note:



1. Reinforced fittings displayed in sizing DN 100 and DN 150 only.
2. Fabrication in larger diameter or 'special orders' may be possible. Refer Manufacturer for confirmation of availability.
3. Reinforced fittings are not categorised in AS/NZS 1260. Approval of reinforced fittings is subject to individual product assessment by SA Water.

3.2.1.2 Standard Fittings

Plain Bend (F-F, M-F) 	Plain Bend (F-F, M-F) 	Angled Junction (F-F, M-F) 	Reducing Junction (F-F, M-F) 
DN 225 & 300 90°	DN 225 & 300 45°	DN 225 & 300 45°	DN 225 & 300 45°
Manufacturers			
Aymroo			Aymroo
Iplex Pipelines	Iplex Pipelines	Iplex Pipelines	Iplex Pipelines
Pipe King		Pipe King	Pipe King
Plastec	Plastec	Plastec	Plastec
Vinidex	Vinidex	Vinidex	Vinidex
Holman	Holman	Holman	Holman

Eccentric Taper 	Straight Coupling Threaded 	Threaded Cap 	Glue On Cap 
DN 225 & 300	DN 100 & 150	DN 100 & 150	DN 100 – 300
Manufacturers			
Aymroo			Aymroo
Iplex Pipelines	Iplex Pipelines	Iplex Pipelines	Iplex Pipelines
	Pipe King	Pipe King	Pipe King
Plastec	Plastec	Plastec	Plastec
Vinidex	Vinidex	Vinidex	Vinidex
Holman	Holman	Holman	Holman



3.2.1.2 Standard Fittings (Cont'd)



Slip Coupling 	Drop Bend 	Riser Junction 	
DN 100 – 150	DN 100 – 225	DN 225 & 300	
Manufacturers			
	Aymroo	Aymroo	
Iplex Pipelines			
Plastec	Plastec		
Vinidex			
Holman	Holman	Holman	

3.2.1.3 Flexible Fittings

DN 100, 150, 225
Manufacturers
Plastec

3.2.2 Polypropylene (Structured Wall) (PP)

<p>Plain Bend</p> 	<p>Tee 'T' Junction</p> 	<p>Angled Junction & Reducing Junction</p> 
<p>DN 150 – 300 45° - 90°</p>	<p>DN 150 – 300 88° - 90°</p>	<p>DN 150 – 300 45°</p>
Manufacturers		
Iplex Pipelines	Iplex Pipelines	Iplex Pipelines
Vinidex	Vinidex	Vinidex

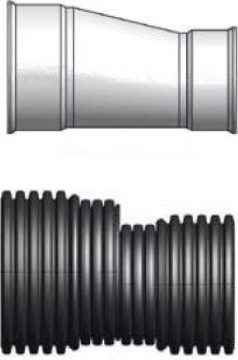
<p>Straight Coupling</p> 	<p>End Cap</p> 	<p>Eccentric Taper</p> 
<p>DN 150 – 300</p>	<p>DN 150 - 300</p>	<p>DN 150 - 300</p>
Manufacturers		
Iplex Pipelines	Iplex Pipelines	Iplex Pipelines
Vinidex	Vinidex	Vinidex

Note:

1. Ends available to accept Polypropylene, PVC Solvent Weld Joint & Vitrified Clay.

3.3 Maintenance Structures

3.3.1 Precast Concrete Maintenance Holes

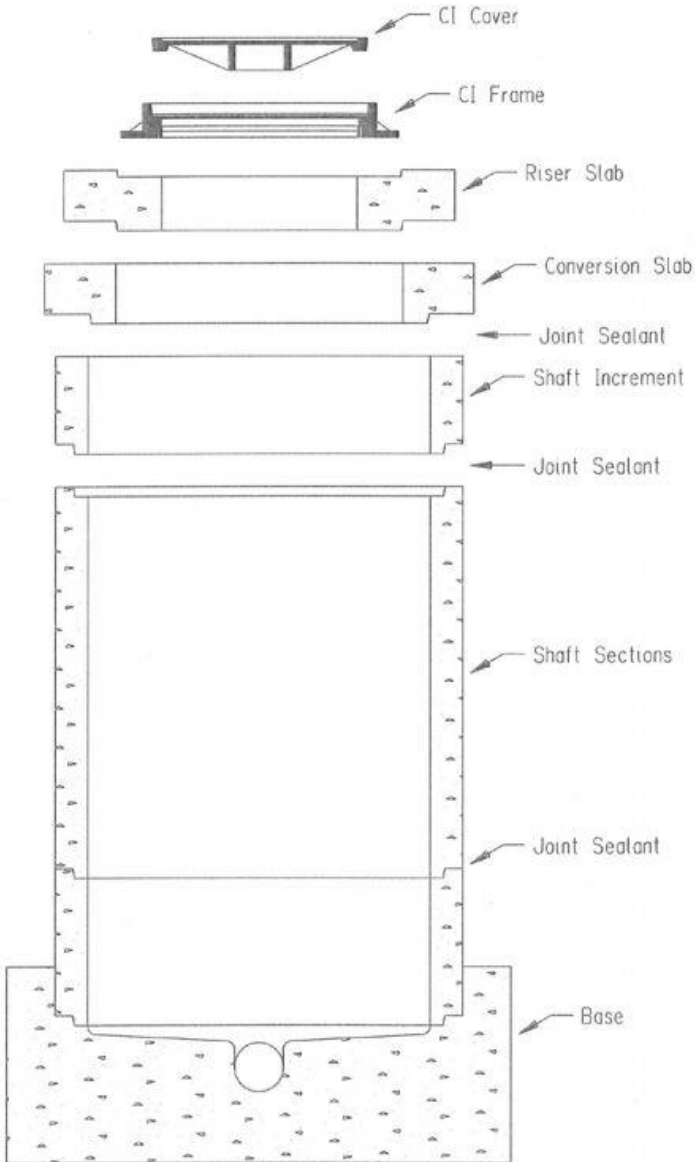
<p>Shall Comply with the following Standard</p>	<p>TS 0600 TS 0710 AS 1302 AS 1303 AS 1304</p>	<p>AS 1379 AS 2758.1 AS 3600 AS 3996 AS 4198</p>
<p>Assembly Specification</p>	 <p style="text-align: center;">Typical Precast Maintenance Hole DN 900/1050/1200/1500</p>	



3.3.1.1 Concrete Shaft Increments

Notes	Sizing availability to be confirmed with Manufacturer	 <p>DN 900, 1050, 1200 & 1500 Available in Heights 300 - 1350</p>
	Manufacturers	
	Civilmart	Humes





3.3.1.2 Concrete Conversion Slabs

<p>Combination Conversion Slab 1050</p> 	<p>Conversion Slab 1200</p> 	<p>Conversion Slab 1500 (Rectangular)</p> 
DN 1050	DN 1200 (Access available in eccentric or central position)	DN 1500
Manufacturer		
Bianco Precast	Bianco Precast	Bianco Precast
Civilmart	Civilmart	Civilmart

3.3.1.3 Concrete Adjustment Rings/Cover Slab

Shaft Increment Height Adjusting Ring 	Riser Slab (Butt Increment) 
DN 1050 & 1200 Thickness 25 - 150	DN 1050 & 1200
Manufacturer	
Bianco Precast	Bianco Precast
Civilmart	Civilmart

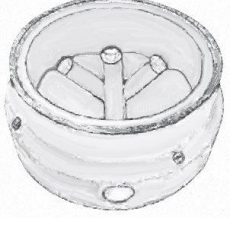
3.3.1.4 Concrete Base

Non-Pre-Benched Base 	Base Pre-Benched Straight 	Base Pre-Benched 4 Way 45° 	Base Pre-Benched 4 Way 90° 
DN 1200	DN 1050	DN 1050	DN 1050
Manufacturer			
Civilmart	Civilmart	Civilmart	Civilmart

Refer Clause [5.1.1](#) for Maintenance Hole Covers

3.3.1.5 Plastic Maintenance Holes

<p>Shall Comply with the following Standard</p>	<p>TS 0600 WSA 137</p>	<p>DIN EN 476 DIN EN 13598-2</p>
<p>Assembly Specification</p>		
<p>Notes</p> <p>For buoyancy safety, the maximum groundwater level above pipe bottom is 5 metres</p>	<p style="text-align: center;">Typical Plastic Maintenance Hole DN 1000</p>	

3.3.1.6 Bearing/Support Ring

Shall Comply with the following Standard	WSA 137 (2019) DIN EN 476 DIN EN 13598-2.		
Notes	Sizing availability to be confirmed with Manufacturer	Polymer Ring	Concrete Ring
Manufacturer			
		Rehau	Iplex

3.3.1.7 Cone

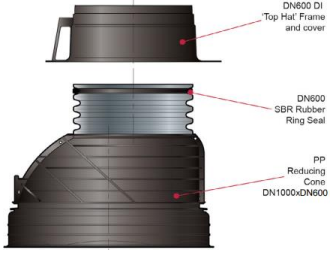
Shall Comply with the following Standard	WSA 137 (2019) DIN EN 476 DIN EN 13598-2.		
Notes	Sizing availability to be confirmed with Manufacturer		
Manufacturer			
		Rehau	Iplex

3.3.1.8 Chamber Riser Rings

Shall Comply with the following Standard	WSA 137 (2019) DIN EN 476 DIN EN 13598-2.		
Notes	Sizing availability to be confirmed with Manufacturer		
Manufacturer			
		Rehau	Iplex

3.3.1.9 Standard Bases

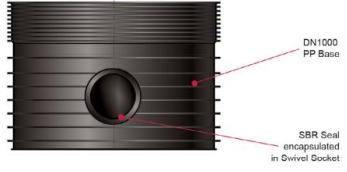
Shall Comply with the following Standard	WSA 137 (2019) DIN EN 476 DIN EN 13598-2.		
Notes	Sizing availability to be confirmed with Manufacturer		
Manufacturer			
		Rehau	Iplex

3.3.1.10 Riser Connection – for PVC and PP

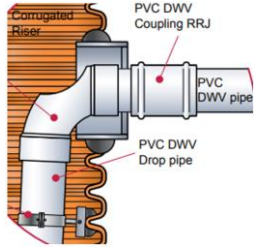
Shall Comply with the following Standard	WSA 137 (2019) DIN EN 476 DIN EN 13598-2.		
Notes	Sizing availability to be confirmed with Manufacturer		
Manufacturer			
		Rehau	Iplex

3.3.2 Maintenance Shafts

Shall Comply with the following Standard	AS/NZS 4999 WSA 137
---	------------------------

<p>Assembly Specification</p>	
<p>Notes</p> <p>Manufacturers have differing restrictions on the depth for use of their Maintenance Shafts</p> <p>Refer Clause 5.2.1 for Maintenance Shaft Covers</p>	<p>Refer to Clause 3.1.1 & 3.1.2 For connecting pipes.</p> <p>The Riser shaft shall be U PVC and shall include a combination of components from 3.1.1 and 3.2.1</p> <p>Maximum invert shall be:</p> <ul style="list-style-type: none"> ○ Aymroo - 5 metres ○ SMS - 4 metres ○ Rehau - 4 metres. ○ Smartstream - 5 metres ○ Iplex - 5 metres

3.3.2.1 U PVC Shaft Bases



<p>Terminal</p> 	<p>Straight</p> 	<p>45° Junction</p> 
<p>DN 150 & 225 90°</p>	<p>DN 150, 225 & 300</p>	<p>DN 150 x 150 x 150 225 x 225 x 150 300 x 300 x 300</p>
Manufacturer		
Aymroo	Aymroo	Aymroo

<p>45° Corner</p> 	<p>15°, 22.5°, 30°, 45° & 90°</p> 	<p>CAMS (Central Access MS)</p> 
<p>DN 300</p>	<p>DN 150 & 225</p>	<p>DN 150 & 225</p>
Manufacturer		
Aymroo	Aymroo	Aymroo



3.3.2.2 Polypropylene Rubber Ring Shaft Bases

Straight			Reducer straight	
				
DN 150 Pipe, 300 Access	DN 150 Pipe, 375 Access	DN 150/225/300 Pipe, 225/300 Access	DN 150 Pipe, 225 Reducer Access	DN 150 Pipe, 300 Reducer Access
Manufacturer				
Rehau		Iplex (with swivel sockets)		SMS

Multi Junction		Reducer Multi Junction		
				
DN 150 Pipe, 300 Access	DN 150 Pipe, 375 Access	DN 150 Pipe 225 Reducer Access	DN 150 Pipe 300 Reducer Access	
Manufacturer				
Rehau		Iplex (with swivel sockets)		SMS

Terminal	Junction	Coupling
		
DN 150 x 225 90°	DN 150 x 225, DN 150 x 300 DN 225 x 225	DN 150, 225 & 300
Manufacturer		
SMS	SMS	SMS

3.3.2.3 Polyethylene Shaft Bases

<p>Notes</p> <p>Pipe - DN 150 & 225; Shaft - DN 225 & 300</p> <p>Angles - Straight, 15°, 22.5°, 30° & 45°</p>			
	PE Pipe ends	PVC Pipe ends	Terminal
Manufacturer			
Smartstream Technologies Pty Ltd			



3.3.2.4 Riser Shaft (U PVC)

Refer to the following Clauses for authorised pipe and fittings:

- Authorised Pipe [3.1.1](#)
- Authorised Fittings [3.2.1](#)

3.3.2.5 Bends

3.3.2.5.1 Vario Bends (U PVC)

Notes DN 150 only		
	Long Radius (3000)	Short Radius (675)
Manufacturer		
Aymroo		

3.3.2.5.2 Polypropylene Bends

Notes DN 225 only. 15°, 30° & 45°	
Manufacturer	
SMS	

3.3.3 Inspection Opening/Inspection Point

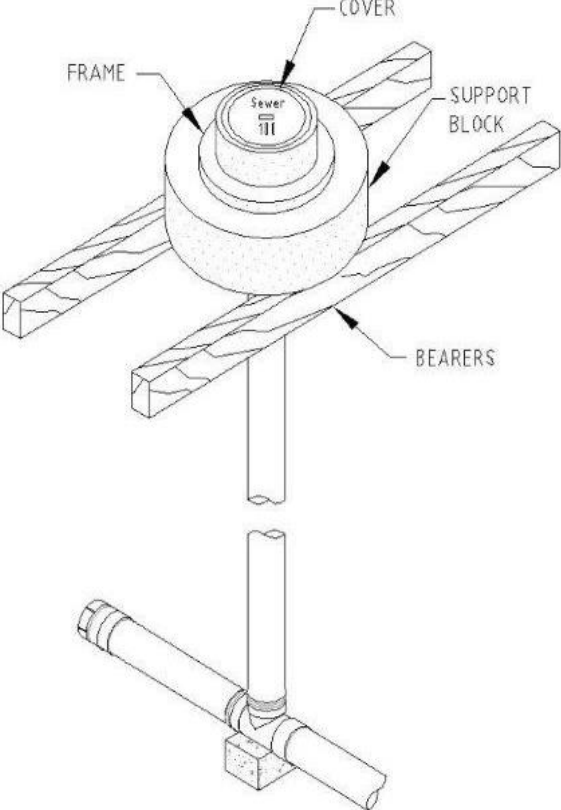
<p>Shall Comply with the following Standard</p>	<p>AS/NZS 3996</p>
<p>Assembly Specification</p>	

3.3.3.1 Inspection Opening

3.3.3.1.1 U PVC Pipes & Fittings

- Refer Clause [3.1.1](#) for authorised Pipe (DN 150 ONLY)
- Refer Clause [3.2.1](#) for authorised Fittings (DN 150 ONLY)
- Refer Clause [5.3.1](#) for Inspection Opening Covers

3.3.3.2 Inspection Point

3.3.3.2.1 U PVC Pipes & Fittings

- Refer Clause [3.1.1](#) for authorised Pipe (DN 100 & 150 ONLY)
- Refer Clause [3.2.1](#) for authorised Fittings (DN 100 & 150 ONLY)
- Refer to Clause [5.4.1](#) for Inspection Point Covers

4 Pressure Pumping Main

4.1 Pipes

4.1.1 Oriented PVC (O PVC) & Modified PVC (M PVC)

Shall Comply with the following Standard	AS/NZS 4441		 <p>DN 100 - 200</p>
	AS/NZS 4765		
Notes	All pipes shall be CREAM colour		
	All pipes and fittings shall be Rubber Ring Jointed.		
	All fittings are to be Ductile Iron FBE coated.		
	PN 16 Series 2 unless otherwise specified		
Manufacturers	David Moss Group	PVC M	
	Iplex Pipelines	PVC M	Blue Rhino
		PVC O	Apollo Blue
	Micron Pipelines	PVC M	
		PVC O	
	Viadux	PVC M	Tuf-Flo
	Vinidex	PVC M	Hydro Blue
		PVC O	Supermain

4.1.2 Polyethylene Pipe

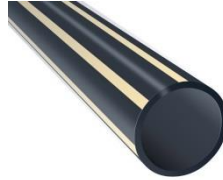
Shall Comply with the following Standard	AS/NZS 4130	 <p>OD 125 - 250</p>	
	AS/NZS 2032		
Notes	PE100 and PN 16 minimum		
	All pipes shall be: BLACK with CREAM stripe or all CREAM in colour		
Manufacturers	Refer Clause 3.1.7		

4.1.3 Mild Steel Polyurethane Lined Pipe

Shall Comply with the following Standard	AS 1281 AS 1579 AS 4321	 DN 100 - 200
Notes		
Manufacturers	Refer Clause 3.1.5	

4.1.4 Ductile Iron Pipe (DI)





Shall Comply with the following Standard	AS 3680 AS 3681 AS/NZS 2280	 DN 100 - 200
Notes	Polyethylene sleeving shall be used for corrosion protection coloured CREAM	
Manufacturers	Refer Clause 0	

4.2 Fittings





4.2.1 Ductile Iron (FBE Coated)

Shall Comply with the following Standard	AS/NZS 2280 AS 4087
Notes	Series 2, PN 16 unless specified otherwise BLACK or BLUE coloured fittings are acceptable for use in Pressure Sewer Systems. Sizing for Ductile Iron fittings up to DN 200. Refer TS 0503, for complete Range of Ductile Iron (FBE Coated) Fittings, together with manufacturer, notes and specifications.

Tee “T”

<p>SOC/SOC Branch SOC</p> 	<p>SOC/SOC Branch FLG</p> 	<p>FLG/FLG Branch FLG</p> 	<p>SPI/SPI Branch SPI</p> 
--	--	---	--

Bends

<p>SOC/SOC</p> 	<p>FLG/FLG</p> 	<p>FLG/SOC</p> 	<p>FLG/SPI</p> 
--	--	---	--

Connectors



Reducer/Taper



Hydrant Tee “T”



Supported Bends



Flanged Extension Pipe (Flanged Connector)

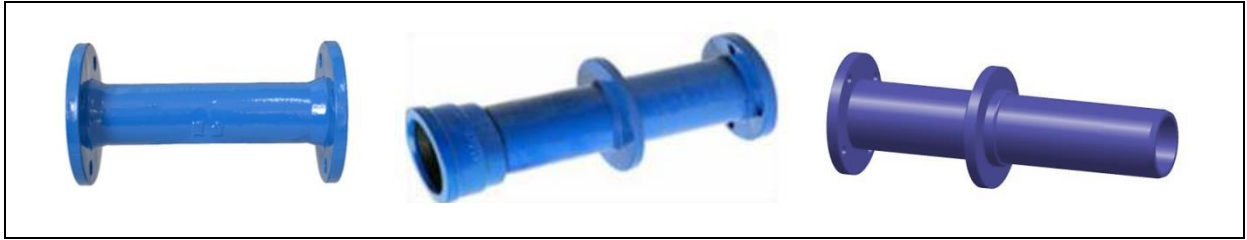

Cap



Flanges





Eccentric Reducer Flange / Flange



Tee Scour

SOC/SOC Branch FLG		SPI/SPI Branch FLG	
			
DN 80 - 375		DN 80 – 375	
Manufacturers	Iplex Pipelines		
	Viadux		
	Vinindex	SLII PN16	SL PN35

Flange Flared Fittings

FLG/FLR Bend 	FLG/FLR 
---	--

4.2.2 Polyethylene Fittings

Shall Comply with the following Standard	AS/NZS 4129
Notes	<p>Only PE products:</p> <p>identified in SA Water documents, and obtained from one of the listed Manufacturers, or their Agent, are approved for use.</p> <p>Pipe sizing shall be confirmed with the SA Water Representative.</p> <p>Approved jointing methods shall be Electrofusion or Butt Weld.</p> <p>Butt welding shall only be permitted by welders authorised by SA Water. For details refer:</p> <p style="padding-left: 40px;">Factory welding- TS 0503, 9.1.1.</p> <p style="padding-left: 40px;">Site welding - TS 0503, 9.1.2.</p> <p>Electrofusion Welding shall only be permitted by qualified welders. Required qualification is PMBWELD302B – Electrofusion Weld.</p> <p>Fabrication and deliverables shall be in accordance with WSCM 4005-30005-08.</p>

4.2.2.1 Flange / Flange with Thrust Ring & 80 Flange Fire Plug Offtake

	
Manufacturers	Refer TS 0503, for manufacturer, notes and specifications.

4.2.2.2 Electrofusion Couplings

Shall Comply with the following Standard	AS/NZS 4129	
Notes	Only <u>specific</u> SDR11 Electrofusion fittings are approved.	
Manufacturers	Refer TS 0503, for manufacturer, notes and specifications.	

4.2.2.3 Electrofusion Puddle Flange

Notes OD 160 - 250 Only to be installed in accordance with Plasson's installation instruction for this product and within the guidelines of PIPA document POP 001		
Manufacturers	Plasson	

Refer TS 0503, Clause **4.2.3** for manufacturer, notes and specifications

4.2.2.4 Butt Weld Fittings

Shall Comply with the following Standard	AS/NZS 4129
Notes Only specific SDR11 Spigot fittings are approved.	
Manufacturers	Refer TS 0503, for manufacturer, notes and specifications

4.3 Miscellaneous Fittings

4.3.1 Camlock Couplings



Shall Comply with the following Standard	AS 2638 WSA PS 262	 DN 50 - 100
Notes	Metal or Polyethylene Coupling (Type F) with BSP male thread Dust Cap (Type DC)	
Manufacturers	Refer TS 0503, for manufacturer, notes and specifications	

4.4 Mains Couplings

4.4.1 Multi Fit Couplings

Shall Comply with the following Standard	AS/NZS 4158 WSA PS 270
Notes	Grade 316 stainless steel bolts having a life expectancy of over 50 years. Not to be used on polyethylene pipes. Bitumen coated end clips shall not be used.

4.4.1.1 Straight, Stepped & Adaptor Flange Couplings

		
DN 80 - 200	DN 80 - 200	DN 80 - 200
Manufacturers	Refer TS 0503, for manufacturer, notes and specifications	

4.4.1.2 Gibaults

	
DN 80 - 200	
Manufacturers	Refer TS 0503, for manufacturer, notes and specifications

4.5 Mains Tapping Fittings

4.5.1 Ductile Iron (FBE Coated) Pre-Tapped Connectors

Shall Comply with the following Standard	AS/NZS 4158 WSA PS 201	
Notes	Single Tapping Each Side. DN 100 x (20 – 50BSP) DN 150 x (20 – 50BSP) DN 200 x (50BSP)	
Manufacturers	Refer TS 0503, for manufacturer, notes and specifications	

4.5.2 Tapping Saddles - Low Pressure to Gravity Sewer

For tapping saddles approved for low pressure connections to gravity sewer, refer TS 0503 - Clause 5.2.1

4.5.3 Resilient Seat Gate Valve Double Flange

Shall Comply with the following Standard	AS/NZS 2638-2 WSA PS 260	
Notes	1.6MPa (PN 16) unless otherwise specified Clockwise Closing Not for Buried Applications DN 80 - 200	
Manufacturers	Refer TS 0503, for manufacturer, notes and specifications	

4.5.4 Swing Check

Shall Comply with the following Standard	AS 4794 WSA PS 264	
Notes	1.6MPa (PN 16) unless otherwise specified. With Extended Spindle & Counterweight Not for Buried Applications DN 80 - 200	
Manufacturers	Refer TS 0503, for manufacturer, notes and specifications	

4.5.5 Fire Hydrant (For Air Bleed)

Shall Comply with the following Standard	AS 2419.2	
Notes	DN 80	
Manufacturers	Refer TS 0503, for manufacturer, notes and specifications	

4.5.6 Main Cock (For Air Bleed)

Shall Comply with the following Standard	AS 3688	
Notes	Tube DN 20	
Manufacturers	Refer TS 0503, for manufacturer, notes and specifications	



5 Covers



5.1 Maintenance Hole

5.1.1 Cast Iron Cover & Frame

Shall Comply with the following Standard	AS/NZS 3996 (2019)
Notes	<p>All trafficable covers shall comply with AS/NZS 3996 Class D. In compliance with AS/NZS 3996 (2019), when installed on freeways/motorways, Class E shall be used.</p> <p>Non-Trafficable covers shall comply with AS/NZS 3996 Class B.</p> <p>Cover to be marked SEWER</p> <p>Concrete Riser Slab/Conversion Slab is required to adjust to the required height of Maintenance Hole.</p> <p>Hinged covers shall only be installed, with the hinge facing oncoming lane traffic.</p> <p>For Cover Supports Slabs refer 3.3.1.2 Concrete Conversion Slabs.</p>

5.1.1.1 Trafficable

<p>Circular, Ductile Iron</p>  <p>DN 600 (for DN 900, 1050 & 1200)</p>	<p>E 400, Composite Material</p>  <p>DN 600 (for DN 900, 1050 & 1200)</p>
Manufacturers	
Bianco Precast (Class D)	Terra Firma (Class D)
Civilmart (Class D)	
Ducast DA 4 - with rubber seals (Class D and E)	
Webforge (Class D)	

<p>Maestro (Lockable)</p>  <p>For DN 900, 1050 & 1200</p>	
<p>EJ with rubber seals (Class D and E)</p>	<p>Bianco Precast No 5 Access Cover For DN 1500 (Class D)</p>
	<p>Ducast DA 1 - with rubber seals 600 x 600 (Class D and E)</p>

5.1.1.2 Non Trafficable

 <p>For DN 900, 1050 & 1200</p>
Manufacturers
Bianco Precast
Civilmart
Webforge
Ducast



5.2 Maintenance Shaft

5.2.1 Cast Iron Cover & Frame

Notes	The one-piece lid shall be used for Maintenance Shafts. Cover shall be marked SEWER.	
<p style="text-align: center;">Half Height</p> 	<p style="text-align: center;">Trafficable Cover Support Slab</p> 	<p style="text-align: center;">Non-Trafficable Cover Support Ring</p> 
	1200 x 800 x 170	600 x 140 Thick
Manufacturers	Refer TS 0503, for manufacturer, notes and specifications	





5.3 Inspection Opening

5.3.1 Cover & Support Items (Top Stones)

<p style="text-align: center;">Cover Frame and Support Block</p> 	<p style="text-align: center;">Bearer (Hardwood)</p>  <p style="text-align: center;">Hardwood bearers are to be rated a minimum of 8 on the Janka scale</p>
<p>150 mm</p> <p>Class D Load Rated</p>	<p>Hardwood 75 x 125 x 1200</p>
Manufacturers	
Bianco Precast	
Civilmart	
Viadux	



5.4 Inspection Point

5.4.1 Cover and Support Items (Top Stones)

<p>Cover Frame and Support Block</p>  	<p>Cover Frame and Support Block</p>  	<p>Bearer (Hardwood or Recycled Plastic)</p>  <p>Hardwood bearers are to be rated a minimum of 8 on the Janka scale</p>
<p>100 mm Class B Load Rated</p>	<p>150 mm Class D Load Rated</p>	<p>Hardwood 75 x 125 x 1800 Plastic 50 x 75 x 1800 Plastic 40 x 70 x 1200</p>
Manufacturers		
Bianco Precast	Bianco Precast	
Civilmart	Civilmart	
Viadux	Viadux	

5.5 Street Box / Heavy Duty (Type A)

5.5.1 Chamber, Lid and Concrete Support Spacer

<p>Full Height</p> 	
<p>Notes</p>	<p>Used for Pumping Main Air Valves.</p> <p>Cover to be marked SEWER Recommended concrete slab 1200 x 800 x 125 thick or 800 x 800 x 150 thick or Circular ring 600 x (75 or 140) thick</p>
<p>Manufacturers</p>	<p>Refer TS 0503, for manufacturer, notes and specifications</p>

6 Signs and Tape

6.1 Signs

Specification	SA Water - WSCM Drawing	
Notes	For use on: Sewer Pump-Out Branch Sewer Stop Valve Sewer Air Valve	
Manufacturers	Peninsula Casting	
	Ferretti International	

6.2 Underground Warning Tape

Shall Comply with the following Standard	AS/NZS 2648.1 WSA PS 318 WSA PS 319	
Specification	'CAUTION BURIED SEWER MAIN BELOW' – Detectable tape required	
Notes	When used for Sewer Pumping Mains Underground - Non-Detectable	
Manufacturers	Heatech	
	Romac Trading	
	Tapex	
	Viadux	