

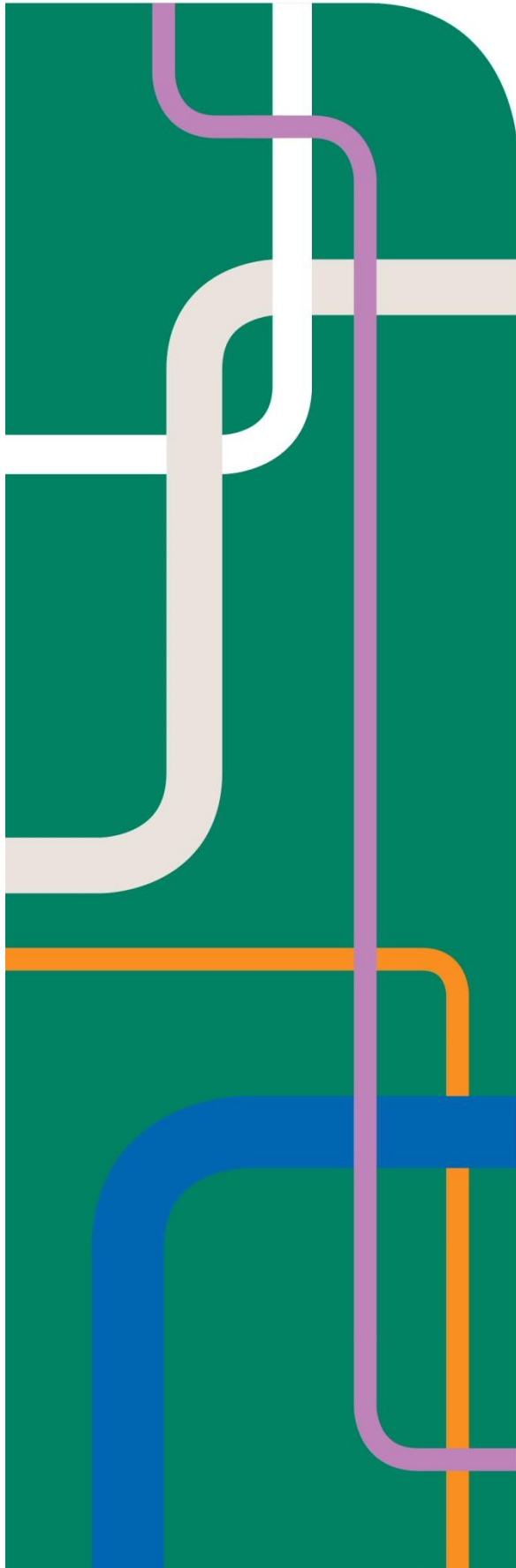

Government
of South Australia



Engineering Services

Authorised Products **TS 0504**

Packaged Sewer Pump Stations

Revision: 1.0
Date: 08 April 2016

Copyright

This Standard is an intellectual property of the South Australian Water Corporation. It is copyright and all rights are reserved by SA Water. No part may be reproduced, copied or transmitted in any form or by any means without the express written permission of SA Water.

The information contained in this Standard is strictly for the private use of the intended recipient in relation to works or projects of SA Water.

This Standard has been prepared for SA Water's own internal use and SA Water makes no representation as to the quality, accuracy or suitability of the information for any other purpose.

Application & Interpretation of this Document

It is the responsibility of the users of this Standard to ensure that the application of information is appropriate and that any designs based on this Standard are fit for SA Water's purposes and comply with all relevant Australian Standards, Acts and regulations.

Users of this Standard accept sole responsibility for interpretation and use of the information contained in this Standard. Users should independently verify the accuracy, fitness for purpose and application of information contained in this Standard.

Only the current revision of this Standard should be used which is available for download from the SA Water website.

Significant/Major Changes Incorporated in This Edition

This is the first issue of this Technical Standard.

The document is based upon the January 2015 edition of Authorised Items for Sewer Systems.



Document Controls

Revision History

Revision	Date	Author	Comments
1.00	08 April 2016	R Pearce	

Template: Technical Standard Version 5.00, 01/03/2016

Approvers

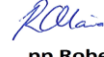
Role	Signature and Date
Responsible Discipline Lead Tom Galek	7/04/2016 X  ----- Signer's Name Signed by: GA112117
Manager Engineering Technical Services Murat Aksoy	7/04/2016 X  ----- Signer's Name Signed by: AK003305
Senior Manager Engineering Services Richard Gray	7/04/2016 X  pp Robert Alaia ----- Signer's Name Signed by: AL003250

Reviewers

Role	Name	Revision	Review Date

Contents

1	Introduction.....	5
1.1	Purpose	5
1.2	Glossary.....	5
1.3	References	5
1.3.1	Australian and International.....	5
1.3.2	SA Water Documents.....	6
1.4	Definitions.....	6
1.5	Disclaimer	6
2	Scope.....	8
3	Package Pump Station Information.....	9
4	Package Pump Station Providers.....	10
4.1	Caprari/CPC.....	10
4.2	Global Water.....	11
4.3	Xylem	12
5	Educt Vents.....	13

1 Introduction

This Document lists conforming products approved for installation within SA Water's infrastructure networks.

The products listed have been approved after their evaluation based upon the SA Water product appraisal procedure.

Approved products shall only be obtained from the listed manufacturer or their authorised agent.

1.1 Purpose

this document for confirmation of products SA Water has authorised for use.

Product Manufacturers, suppliers and other stakeholders may also use the information as reference material.

SA Water personnel should source items from the Store. If not stocked they should procure by means of:

- utilising the relevant SA Water Period Contract or Standing Offer Arrangement,
- where an item is not covered under a Contract or Standing Offer Arrangement, contacting a relevant Stores or Procurement Officer.

1.2 Glossary

The following glossary items are used in this document:

Term	Description
SA Water	South Australian Water Corporation
TG	SA Water Technical Guideline
TS	SA Water Technical Standard

1.3 References

1.3.1 Australian and International

The following table identifies Australian and International standards and other similar documents referenced in this document:

Number	Title
AS 1260	PVC pipes and fittings for drain, waste and vent (DWV) applications
AS 2032	Code of practice for the installation of PVC pipe systems
AS 3996	Access covers and grates

1.3.2 SA Water Documents

The following table identifies the SA Water standards and other similar documents referenced in this document:

Number	Title
TS 0500	SA Water Authorised Products Water and Sewer Maintenance

1.4 Definitions

The following definitions are applicable to this document:

Term	Description
SA Water's Representative	<p>The SA Water representative with delegated authority under a Contract or engagement, including (as applicable):</p> <ul style="list-style-type: none"> • Superintendent's Representative (e.g. AS 4300 & AS 2124 etc.) • SA Water Project Manager • SA Water Contract Audit Officer • Reticulation Networks Wastewater/ Water Specialist • SA Water nominated contact person
Responsible Discipline Lead	The engineering discipline expert responsible for TS 0504 defined on page 3 (via SA Water's Representative)

1.5 Disclaimer

- SA Water reserves the right to alter, amend or withdraw this document, at any time, without prior notice.
- SA Water does not give preference to any particular make or type of product listed herein. Manufacturers are presented in alphabetical order, not in any order of preference.
- All products listed may be subject to change by the manufacturer. In such circumstances manufacturers are required to notify SA Water of any changes in the design, materials or manufacturing process of any approved product. SA Water is reliant upon manufacturers providing such notification in a timely manner and takes no responsibility for any issue that may arise should a manufacturer fail to do so.
- It is the responsibility of the Designer/ Constructor to ensure selected products are appropriate for the intended application.
- It is the responsibility of the Designer/ Constructor to ensure the product complies with the infrastructure category and meets the relevant Australian standards.
- It is the responsibility of the Constructor to ensure components do not exceed any expiry date.
- Product sizing may vary between manufacturers. Size range provided herein is a guide only and the Designer/ Constructor shall refer to the manufacturer for the product size and availability.
- Pipe and fitting sizing has been limited to DN200 throughout this document. Larger sizes are available from the manufacturer. However, consideration of any product not itemised herein is subject to SA Water approval.

- Information within this document is correct at time of publication E&OE. The date of publication of this document can be found on the front page, and, in the left hand corner of the footer on each subsequent page.

2 Scope

This document specifies products that are authorised for use in packaged sewer pumping stations that are installed in sewer systems.

NOTE: Authorised products for use in pumping mains (from Pumping Stations) up to a maximum size of DN 200 are detailed in TS 0502.

3 Package Pump Station Information

All Fittings Shall Comply With Australian Standard	AS 1260 AS 2032
Specification	
Notes	<ul style="list-style-type: none"> • All package pump stations shall be in accordance with the Sewer Construction Manual (Section M), the Authorised Manufacturer Approved Drawing, and the Approved Design Drawings. • Approved Supplier Pumping Stations come as a Package, inclusive of a concrete sump, separate concrete valve chamber, electrical cabinet and vent. • Pumping Stations Sump shall be installed complete with covers, mechanical plant and equipment, pump bases, guide rails, pipework, level control mechanisms, lifting chains and all ancillary items. • Safety railing is a requirement. • Stations installed in highly corrosion environments shall require all steel items installed inside chamber to be Grade 316 Stainless Steel or other non corrosive materials as approved by SA Water. This includes the Pumps, Guiderrails etc. • Manufacturers are presented in alphabetical order. (Refer Disclaimer).

4 Package Pump Station Providers

4.1 Caprari/CPC

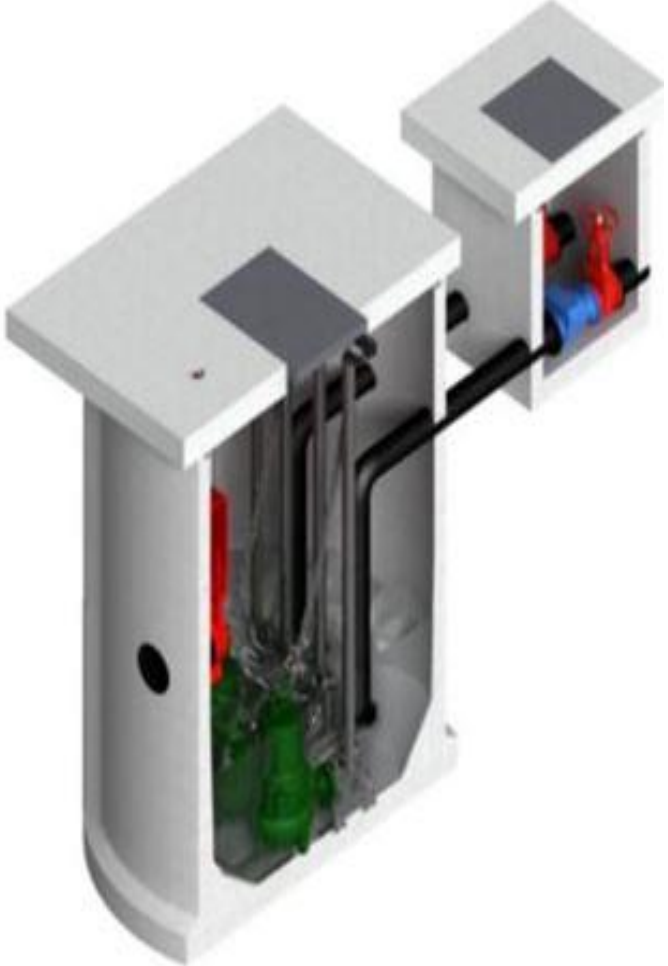
Sump Diameter	
2,000 or 3,000	

[Return to Table of Contents](#)

4.2 Global Water

Sump Diameter	
1,800, 2,100, 2,250 or 3,200	

[Return to Table of Contents](#)

4.3 Xylem

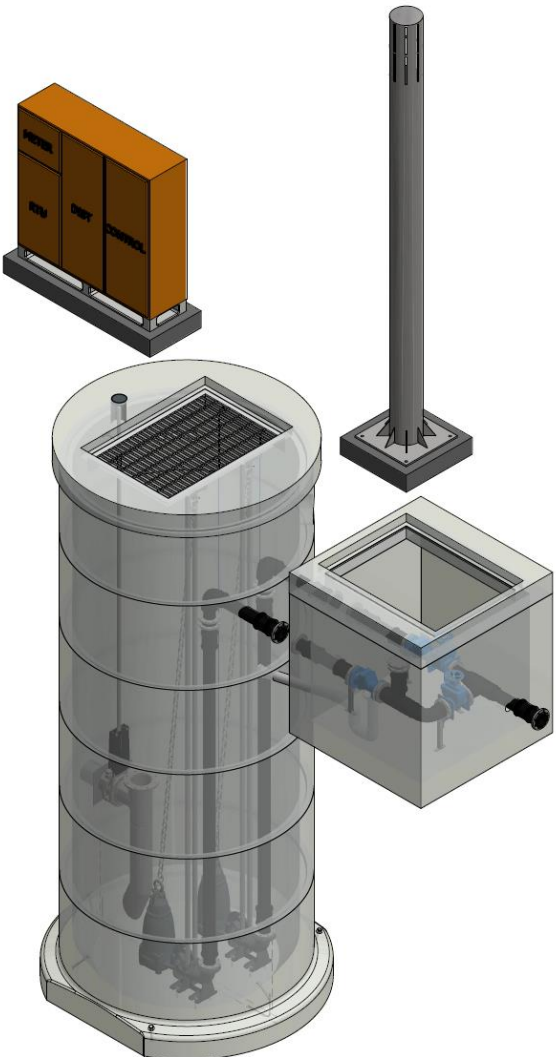
Sump Diameter	
1,800, 2,200 or 3,000	

[Return to Table of Contents](#)

5 Educt Vents

Refer SA Water Authorised Products Water and Sewer Maintenance document, Clause 4.8.1 for manufacturer, notes and specifications.

[Return to Table of Contents](#)